

Owner's Manual

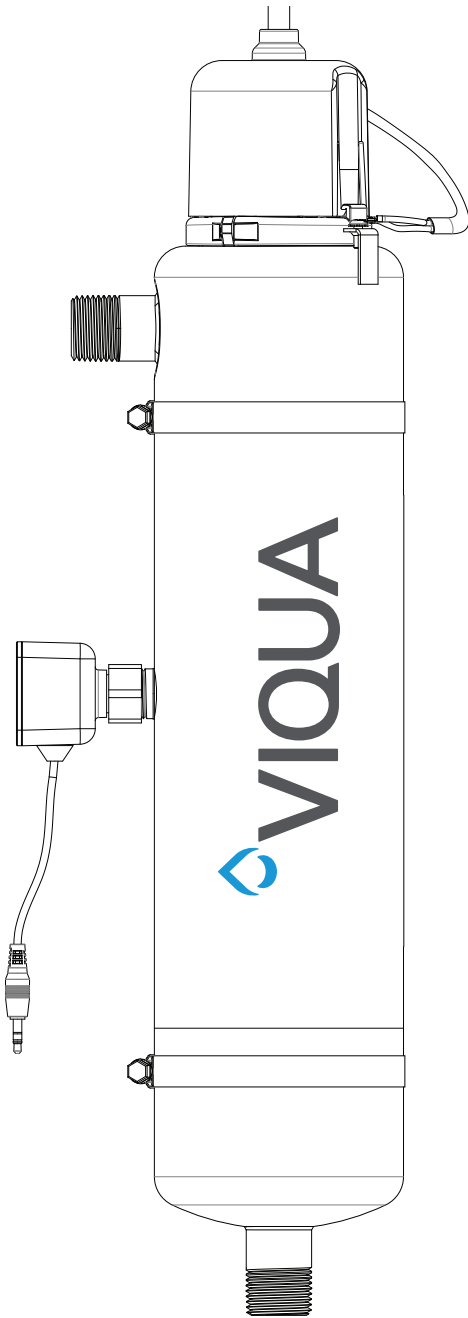

Model:
D4, E4, F4
+ Models:
D4+, E4+, F4+, E4-50+, F4-50+
Validated Models:
D4-V, E4-V, F4-V
D4-V+, E4-V+, F4-V+

Powered by



Congratulations on the purchase of your ultraviolet (UV) water disinfection system! This system uses the most advanced UV technology on the market and is designed to provide you with years of trouble free operation with minimal maintenance required to protect your drinking water from microbiological contaminants.

To ensure ongoing disinfection of your water, UV lamps need to be replaced annually with VIQUA factory-supplied replacements. VIQUA lamps are the result of extensive development resulting in a highly efficient disinfection platform with extremely stable UV output over the entire 9000 hour lifetime. Its success has led to a proliferation of non-genuine copies in the market.

The UV lamp is the heart of the disinfection system, and there should be no compromise when it's time for a replacement.

Why should you insist on genuine factory supplied VIQUA replacement lamps?

- Use of widely available, non-genuine, replacement lamps has been shown to damage the control module of VIQUA UV disinfection equipment.
- An increasing number of calls to VIQUA Technical Support are connected with non-genuine lamps being used (unknowingly) as replacements.
- Damage arising from the use of non-genuine lamps poses a safety risk and is not covered by equipment warranty.
- Unless the UV equipment is equipped with a UV sensor (monitor), it is not possible to verify the UV (invisible) output of replacement lamps.
- Similar appearance to the original lamp and the presence of (visible) blue light does not mean equivalent disinfection performance.
- VIQUA replacement lamps undergo rigorous performance testing and strict quality control processes to ensure that the safety and performance certifications of the original equipment are not compromised.

So, you can see that it's simply not worth the risk! Insist on genuine VIQUA replacement lamps.

















Section 1 Safety Information

These are the original instructions. Please read this entire manual before operating this equipment. Pay attention to all danger, warning, and caution statements in this manual. Failure to do so could result in serious personal injury or damage to the equipment.

Make sure that the protection provided by this equipment is not impaired. Do not use or install this equipment in any manner other than that specified in the installation manual.

1.1 Potential Hazards



Read all labels and tags attached to the system. Personal injury or damage to the system could occur if not observed.

	Waste electrical and electronic equipment (WEEE). This symbol indicates that you should not discard wasted electrical or electronic equipment (WEEE) in the trash. For proper disposal, contact your local recycling/reuse or hazardous waste center.		This symbol indicates not to store any combustible or flammable material close to the system.
	This symbol indicates there is Mercury present.		This symbol indicates that the contents of the transport package are fragile and the package should be handled with care.
	This is the safety alert symbol. Obey all safety messages that follow this symbol to avoid potential injury. When on the equipment, refer to the Operational and Maintenance manual for additional safety information.		This symbol indicates safety glasses with side protection is required for protection against UV exposure.
	This symbol indicates a risk of electrical shock and/or electrocution exists.		This symbol indicates gloves must be worn.
	This symbol indicates the marked equipment may contain a component that can eject forcibly. Obey all procedures to safely depressurize.		This symbol indicates safety boots must be worn.
	This symbol indicates the system is under pressure.		This symbol indicates the operator must read all available documentation to perform required procedures.
	This symbol indicates there is a potential UV hazard. Proper protection must be worn.		This symbol indicates the plumber must use copper piping.
	This symbol indicates the marked item could be hot and should not be touched without care.		This symbol indicates that the system should only be connected to a properly grounded, grounding-type controller receptacle that is protected by a Ground Fault Circuit Interrupter (GFCI).
	This symbol indicates there is a potential for VERY hot water when flow is started.		

Warning: This product may contain chemicals known to the State of California to cause cancer and birth defects or other reproductive harm.

1.2 Safety Precautions

⚠ DANGER

 	<p>Failure to follow these instructions will result in serious injury or death.</p> <ul style="list-style-type: none"> Electric Shock: To avoid possible electric shock, special care should be taken since water is present near the electrical equipment. Unless a situation is encountered that is explicitly addressed by the provided maintenance and troubleshooting sections, do not attempt repairs yourself, refer to an authorized service facility. GROUNDING: This product must be grounded. If it should malfunction or breakdown, grounding provides a path of least resistance for electric current to reduce the risk of electrical shock. This system is equipped with a cord having an equipment-grounding conductor and a grounding plug. The plug must be plugged into an appropriate outlet that is properly installed and grounded in accordance with all local codes and ordinances. Improper connection of the equipment-grounding conductor can result in a risk of electrocution. Check with a qualified electrician or service personnel if you are in doubt as to whether the outlet is properly grounded. Do not modify the plug provided with this system – if it does not fit in the outlet, have a proper outlet installed by a qualified electrician. Do not use any type of adapter with this system. GROUND FAULT CIRCUIT INTERRUPTER PROTECTION: To comply with the National Electrical Code (NFPA 70) and to provide additional protection from the risk of electric shock, this system should only be connected to a properly grounded, grounding-type controller receptacle that is protected by a Ground Fault Circuit Interrupter (GFCI) or to a residual current device (RCD) having a rated residual operating current not exceeding 30 mA. Inspect operation of GFCI as per manufacturer’s suggested maintenance schedule. DO NOT operate the disinfection system if it has a damaged cord or plug, if it is malfunctioning or if it has been dropped or damaged in any manner. DO NOT use this disinfection system for other than intended use (potable water applications). The use of attachments not recommended or sold by the manufacturer / distributor may cause an unsafe condition. DO NOT install this disinfection system where it will be exposed to the weather or to temperatures below freezing. DO NOT store this disinfection system where it will be exposed to the weather. DO NOT store this disinfection system where it will be exposed to temperatures below freezing unless all water has been drained from it and the water supply has been disconnected.
--	--

Safety Information

⚠ WARNING



- During extended periods of no water flow, the water in your chamber can become very hot (Approx. 60 °C) and potentially lead to scalding. It is recommended to run your water until this hot water has been purged from your chamber. Do not allow water to contact your skin during this time. To eliminate this condition, a temperature management valve can be installed at the outlet of your UV system.
- This system contains a UV Lamp. Do not operate the UV Lamp when it is removed from the chamber. Unintended use or damage of the system may result in the exposure of dangerous UV radiation. UV radiation may, even in little doses, cause harm to the eyes and skin.
- Changes or modifications made to this system without the consent of the manufacturer could render the system unsafe for operation and may void the manufacturer's warranty.

⚠ CAUTION



Failure to follow these instructions could result in minor or moderate injury.

- Carefully examine the disinfection system after installation. It should not be plugged in if there is water on parts not intended to be wet such as, the controller or lamp connector.
- Due to thermal expansion concerns and potential material degradation due to UV exposure, it is recommended to use metal fittings and at least 10" of copper pipe on the outlet of your UV chamber.
- **Hg EXPOSURE:** The UV lamp contains mercury. If the lamp breaks, then avoid inhalation or ingestion of the debris and avoid exposure to eyes and skin. Never use a vacuum cleaner to clean up a broken lamp as this may scatter the spilled mercury. Obey local regulations and guidelines for the removal and disposal of mercury waste.

NOTICE



- The UV lamp inside the disinfection system is rated at an effective life of approximately 9000 hours. To ensure continuous protection, replace the UV lamp annually.
- The UV system is not to be used or played with by children. Persons with reduced physical, sensory or mental capabilities, or lack of experience and knowledge, are also not to handle the UV system unless they have been given supervision or instruction.
- This system is intended to be permanently connected to the water lines.
- This system is not intended to be used in or above water or outdoors or used in swimming pools when persons are in the pool.
- **EXTENSION CORDS:** If an extension cord is necessary, use only 3-wire extension cords that have 3-prong grounding-type plugs and 3-pole cord connectors that accept the plug from this system. Use only extension cords that are intended for outdoor use. Use only extension cords having an electrical rating not less than the rating of the system. A cord rated for less amperes or watts than this system rating may overheat. Exercise caution when arranging the cord so that it will not be tripped over or pulled. DO NOT use damaged extension cords. Examine extension cord before using and replace if damaged. DO NOT abuse extension cord. Keep extension cord away from heat and sharp edges. Always disconnect the extension cord from the receptacle before disconnecting this system from the extension cord. Never yank cord to pull plug from outlet. Always grasp the plug and pull to disconnect.
- If the supply cord is damaged, it must be replaced by a special cord or assembly available from the manufacturer or its service agent.
- **SYSTEM PROTECTION:** To protect your Controller, a UL1449 certified (or equivalent) transient voltage surge suppressor is strongly recommended.
- The UV lamp in this system conforms to the applicable provisions of the Code of Federal Regulations (CFR) requirements including, Title 21, Chapter 1, Subchapter J, Radiological Health.
- Read and understand the Owner's Manual before operating and performing any maintenance on this equipment.

1.3 Water Chemistry

Water quality is extremely important for the optimum performance of your UV system. The following levels are recommended for installation:

Water Quality and Minerals	Level
Iron	< 0.3 ppm (0.3 mg/L)
Hardness*	< 7 gpg (120 mg/L)
Turbidity	< 1 NTU
Manganese	< 0.05 ppm (0.05 mg/L)
Tannins	< 0.1 ppm (0.1 mg/L)
UV Transmittance, Standard Models	> 75% (call factory for recommendations on applications where UVT < 75%)
UV Transmittance, 50+ Models	50% - 85%

* Where total hardness is less than 7 gpg, the UV unit should operate efficiently provided the quartz sleeve is cleaned periodically. If total hardness exceeds 7 gpg, the water should be softened. If your water chemistry contains levels in excess of those mentioned above, proper pre-treatment is recommended to correct these water problems prior to the installation of your UV disinfection system. These water quality parameters can be tested by your local dealer, or by most private analytical laboratories. *Proper pre-treatment is essential for the UV disinfection system to operate as intended.*

Section 2 General Information

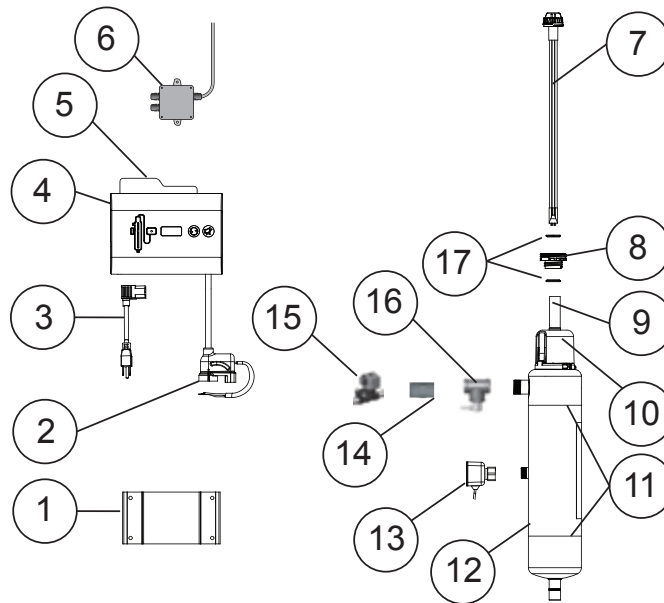

Figure 1 Model Components

Item	Description	Part Number	UV Systems
1	Controller mounting bracket	-	Used for all models
2	Lamp cord	-	Used for all models
3	Power cord	602636 (120V)	Used for 120V models
		602637 (230V)	Used for 230V models
4	Controller (includes controller mounting bracket, reference card, safety cap, lamp cord)	650713-007	Used for all models
5	Reference card	603069	Used for all models
6	Junction box (optional)	650705	Used for all models
7	Lamp (includes O-rings)	602805	D4, D4+, D4-V, D4-V+
		602806	E4, E4+, E4-V, E4-V+, E4-50+
		602807	F4, F4+, F4-V, F4-V+, F4-50+
8	Sleeve bolt	602665	Used for all models
9	Sleeve (includes O-rings)	602732	D4, D4+, D4-V, D4-V+
		602733	E4, E4+, E4-V, E4-V+, E4-50+
		602734	F4, F4+, F4-V, F4-V+, F4-50+
10	Safety cap	603000	Used for all models
11	Chamber clamp(s)	-	Used for all models
12	UV Chamber	650712-001	E4, E4-V
		650712-002	E4+, E4-V+, E4-50+
		650712-005	F4, F4-V
		650712-006	F4+, F4-V+, F4-50+
		650712-013	D4, D4-V
		650712-014	D4+, D4-V+
13	Sensors	650703	Plus models
		650731	E4-50+, F4-50+
14	Flow Restrictor*	440267-R	D4-V, D4-V+
		440268-R	E4-V, E4-V+
		440269-R	F4-V, F4-V+

General Information

Item	Description	Part Number	UV Systems
15	Solenoid valve kit (optional) (includes junction box)	650717-001	D4 (3/4")
		650717-002	E4, E4+, E4-V, E4-V+, F4, F4+, F4-V, F4-V+, E4-50+, F4-50+
16	CoolTouch valve (optional)	650537	D4, D4+, D4-V, D4-V+ (3/4")
		650538	E4, E4+, E4-V, E4-V+, F4+ (1") F4-V (1"), F4-V+ (1"), E4-50+, F4-50+
17	O-ring	002026	Used for all models

To find out what model you have, look at the label on the side of the controller as depicted below:



Figure 2 Model D/E/F- Controller Components

Operating Parameters	D4/D4+/D4-V/D4-V+	E4/E4+/E4-V/E4-V+/E4-50+	F4/F4+/F4-V/F4-V+/F4-50+
No-tools maintenance	Yes	Yes	Yes
Safety cap & special lamp plug	Yes	Yes	Yes
Lamp operation indicator	Yes	Yes	Yes
Controller operation indicator	Yes	Yes	Yes
Sensor operation indicator	D4+, D4-V+	E4-V+, E4+, E4-50+	F4-V+, F4+, F4-50+
Sensor	D4+, D4-V+	E4-V+, E4+, E4-50+	F4-V+, F4+, F4-50+
Reference card	Yes	Yes	Yes
Lamp timer display	Yes	Yes	Yes
Lamp timer reset button	Yes	Yes	Yes
Mute button	Yes	Yes	Yes
Solenoid valve	Optional	Optional	Optional
External control relay	Optional	Optional	Optional

2.1 Dimensions and Layout

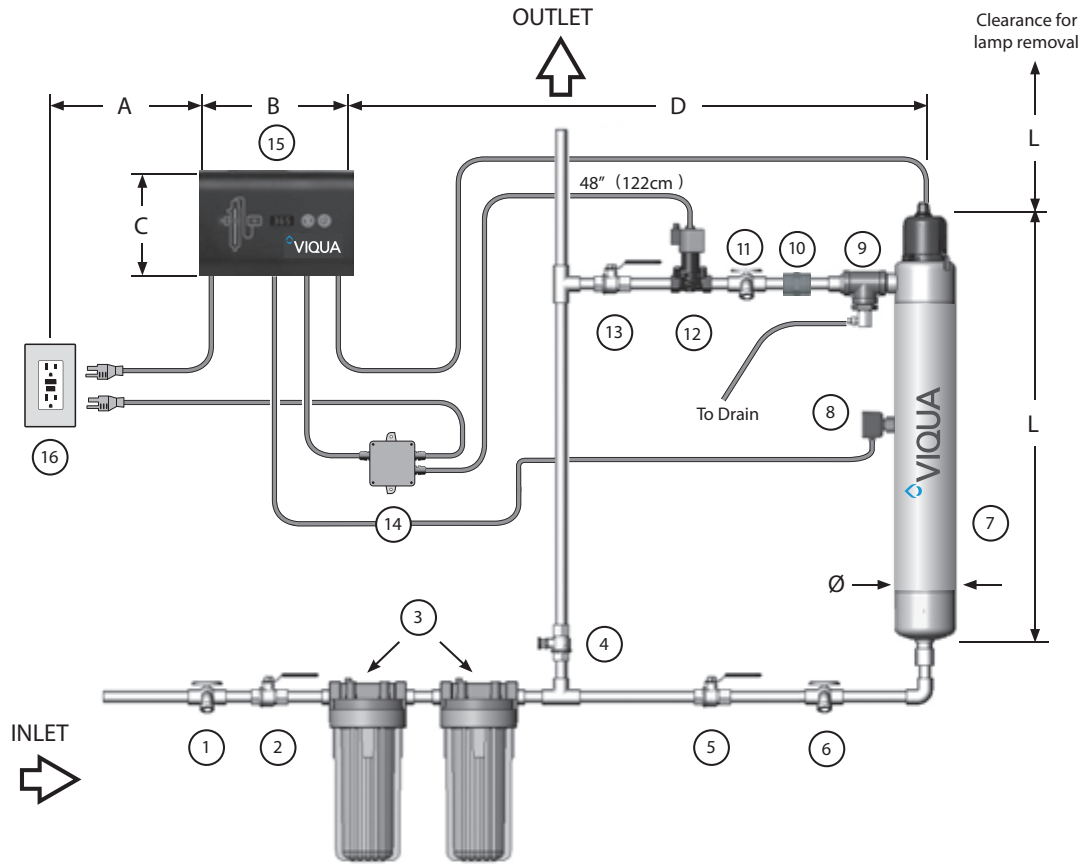

Figure 3 System - Dimension and Layouts

Item	Description	Function
1	Sample valve	Allows for sampling of raw water.
2	Shut-off valve	Required to allow maintenance of pre-treatment equipment.
3	Pre-treatment	Refer to Section 1.3 . Note: A 5 micron (nominal) sediment filter must be installed before the UV system and after any water softening equipment.
4	Bypass shut-off valve	Bypass line and valve are optional. Intended to provide emergency water supply in the event that the UV system is unavailable.
5	Shut-off valve	Required to allow maintenance of UV system.
6	Sample valve	Allows for sampling of water entering UV chamber; necessary in order to confirm water being treated is of adequate quality.
7	UV chamber	Provides disinfection of the water. Must install + model chambers vertically.
8	Sensor	Optional item included with + models. Monitors UV output to ensure proper dose (UV exposure) is being provided.
9	CoolTouch™ valve	Drains water from the chamber that's been warmed by the lamp during periods of no flow.
10	Flow Restrictor	Restricts water from flowing over the maximum NSF certified flow rate ensuring an adequate UV dose is maintained.
11	Sample valve	Allows for sampling of water immediately following UV treatment; necessary in order to confirm proper operation of UV system.
12	Solenoid valve	Optional piece of equipment must be used with a junction box. Allows water supply to be shut-off when proper disinfection cannot be assured. Note: If the ground from your electrical panel is tied to your copper water lines, and you are using a solenoid valve, installation of an approved ground strap is required. This ground strap will maintain continuity between the lines that have been cut to install the solenoid. Check your local electrical code for the correct clamp and cable size.
13	Shut-off valve	Required to allow maintenance of UV system.

Installation

Item	Description	Function
14	Junction box	Optional - Powers solenoid valves, remote alarms and auto-dialers.
15	Controller	Powers and controls the UV lamp and other devices. Provides human interface, displaying information and allowing control inputs (such as muting the audible alarm).
16	Power source	Provides power to the controller. For safety reasons the outlet must be protected by a Ground Fault Circuit Interrupter (GFCI). NOTE: to protect the controller, a UL1449 certified (or equivalent) transient voltage surge suppressor is required.

Model	L	Ø	A (maximum)	B	C	D (maximum)
D4/D4+/D4-V/D4-V+	20.5" (52cm)	4" (10cm)	72" (183cm)	8.5" (22cm)	6" (15cm)	54" (137cm)
E4/E4+/E4-V/E4-V+/E4-50+	30" (76cm)	4" (10cm)	72" (183cm)	8.5" (22cm)	6" (15cm)	54" (137cm)
F4/F4+/F4-V/F4-V+/F4-50+	44.25" (112.4cm)	4" (10cm)	72" (183cm)	8.5" (22cm)	6" (15cm)	54" (137cm)

Section 3 Installation

⚠ CAUTION



Electronic controller must be connected to a Ground Fault Protected Circuit (GFCI) receptacle. Ensure green ground wire ring terminal is securely fastened to ground stud on UV chamber.

3.1 Installing UV System

Prerequisites:

- Determine appropriate indoor location of the controller and chamber. Refer to [Figure 3](#).
- Ensure adequate clearance above chamber to allow for removal of the lamp and sleeve.
- Make sure to turn off the main water supply.
- Mount the system to the wall with appropriate lag bolts through the two mounting holes located on the metal bracket. The supplied lag bolts are suitable for attachment to wood. (Attachments to other materials will require purchasing of alternative hardware).
- Make all necessary plumbing connections. Refer to [Figure 3](#).

Procedure:

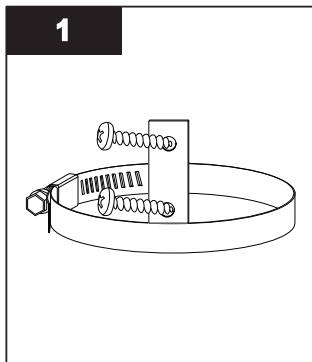

- Screw chamber clamp(s) to the wall (#10 screws recommended.)

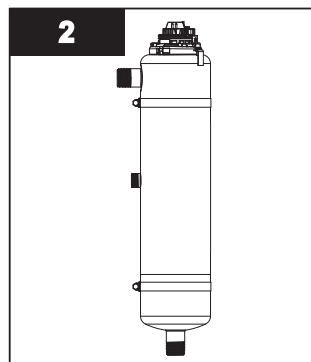

- Insert chamber and tighten clamp(s).
- Make all necessary plumbing connections. Refer to [Section 2.1](#).

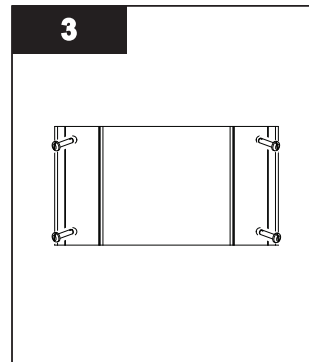

- Mount controller mounting bracket to wall using four #8 screws (not provided).

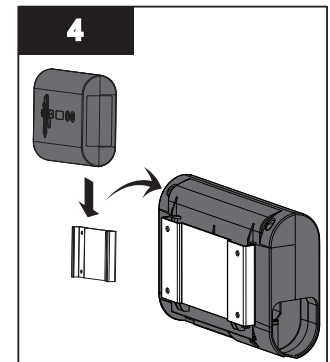

- Slide controller onto mounting bracket.

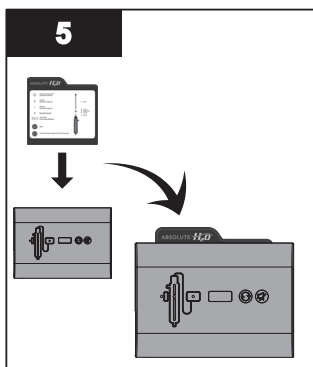

- Insert the reference card between controller and mounting bracket.
Note: Outlet must be protected by a Ground Fault Circuit Interrupter (GFCI).

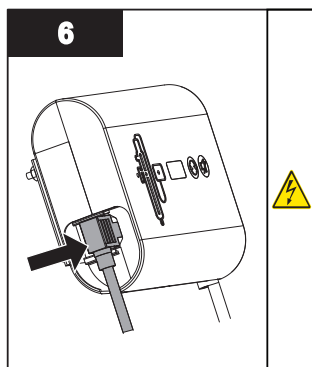

- Connect power cord to controller.
- DO NOT connect the power cord to the GFCI outlet at this time.
- Some lamp assembly may be required. If wires are on outside of glass, lamp/sleeve are separate. Proceed to step 7. If wires are inside glass, skip to step 9.

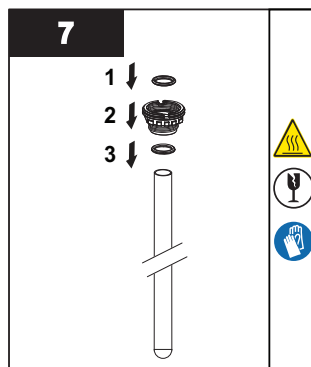

- Install the sleeve bolt with 2 new O-rings to the sleeve.

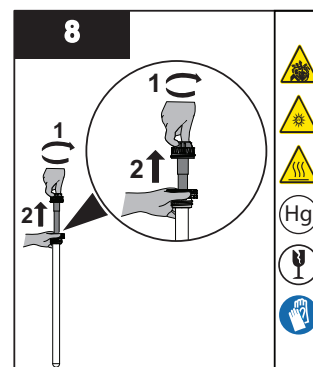

- Install the lamp into sleeve and hand tighten.
Note: Over tightening will break the sleeve.

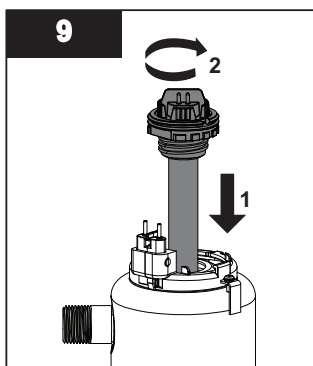

- Insert the lamp/sleeve assembly into chamber, screw hand tight.
Note: Over tightening will break the sleeve.

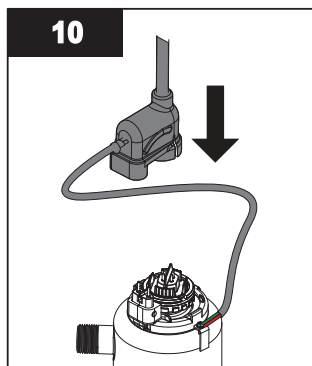

- Connect the green ground wire and red strain relief to the chamber using the grounding screw.
- Align connections by rotating the ring clamp and install the lamp plug.

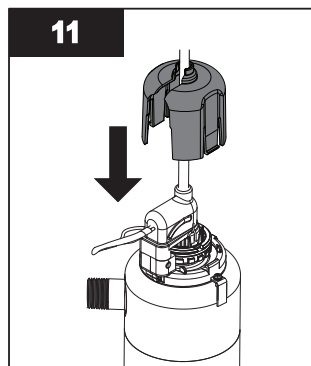

- Insert the safety cap.

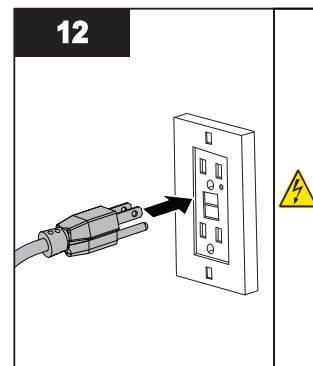

- Connect power.
- Open all faucets and turn on water supply. Inspect for any leaks.
Note: Outlet must be protected by a Ground Fault Circuit Interrupter (GFCI).

3.2 Disinfection Procedure

UV disinfection is a physical disinfection process and does not add any potentially harmful chemicals to the water. As UV does not provide a disinfection residual, it is imperative that the entire distribution system located after the UV be chemically disinfected to ensure that the plumbing system is free from any bacteriological contaminants. The disinfection process must be performed immediately after the UV unit is installed and repeated thereafter whenever the UV is shut down for service, without power, or inoperative for any reason. The procedure for sanitizing the plumbing system is readily accomplished as follows:

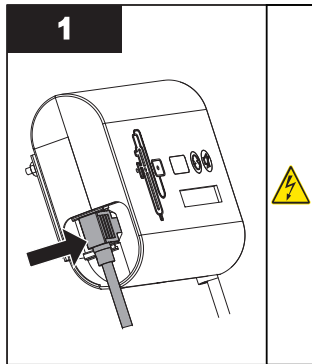

- Ensure only the controller plug is plugged in for entire disinfection process.

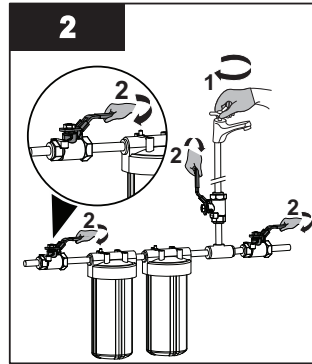

- Shut off the water supply.
- Close each faucet.

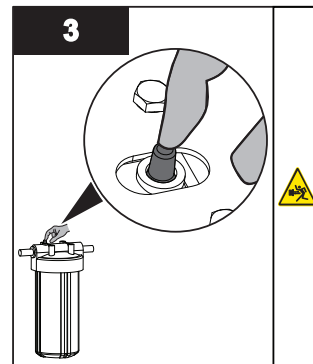

- Press the pressure button to release the pressure from the cartridges.

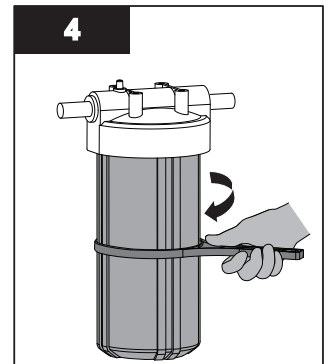

- Remove sump housing(s) using sump wrench.

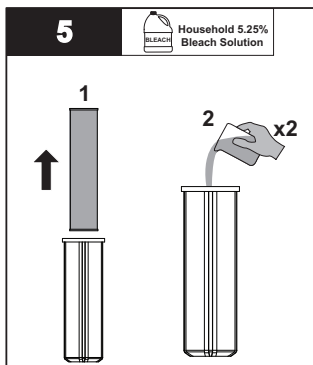

- Remove cartridge(s) and pour 2 cups of household bleach solution into the sump housing(s).

Note: DO NOT use Hydrogen Peroxide.

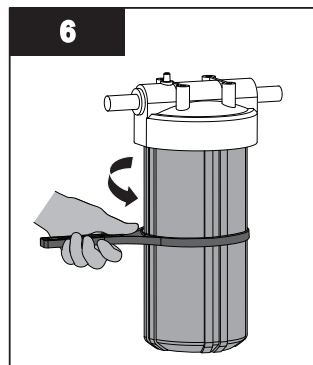

- Reinstall sump only to filter head.

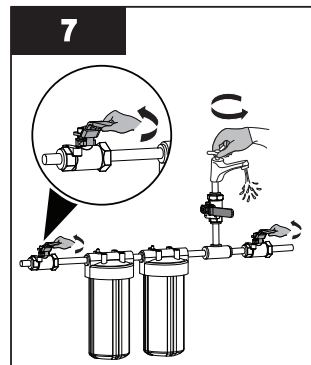

- Turn on water supply.
- Allow water to fill the chamber.

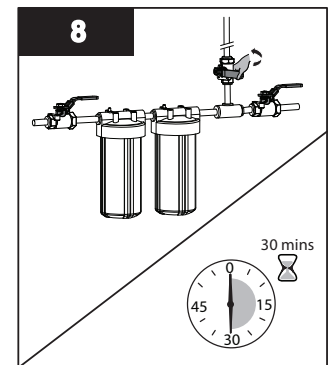

- Turn on the cold water supply followed by hot water (if available) until you smell the bleach.
- Close all faucets and allow bleach to settle in the water lines for 30 minutes.

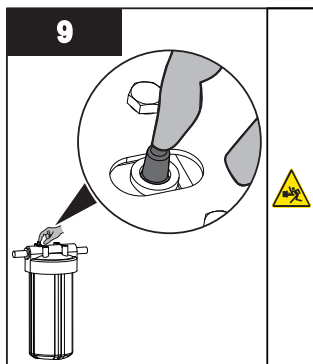

- Press the pressure button to release the pressure.

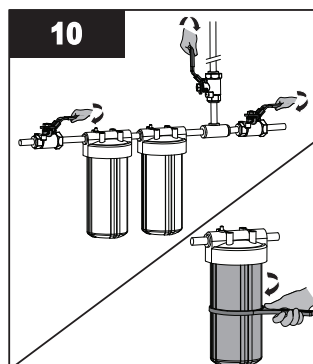

- With all faucets closed, remove sump housing(s) using sump wrench.

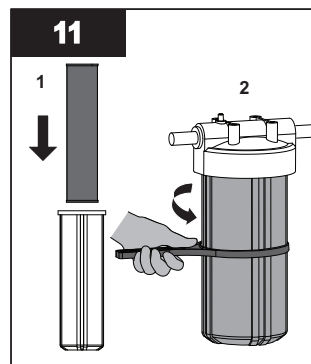

- Reinstall the cartridge(s) into sump housing(s) and connect to the unit.
- Flush all water outlets until bleach can no longer be smelled (at least 5 minutes).

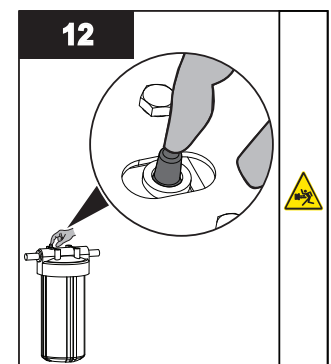

- Press the pressure button to purge air and to complete the disinfection procedure.

Section 4 Operation

4.1 Control Panel

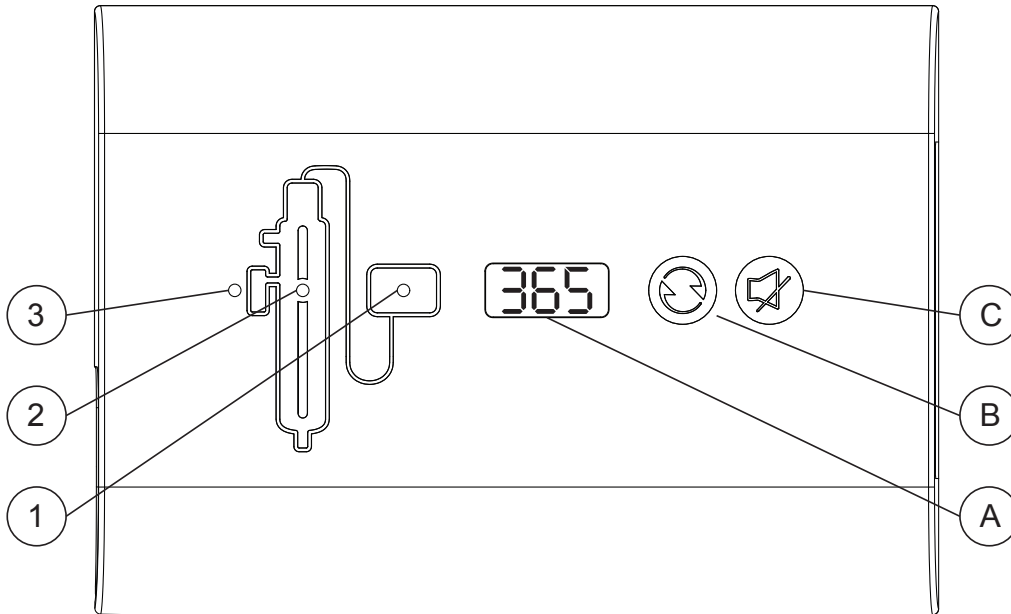

Figure 4 Control Panel

Buttons and Display				
Feature	Description	Function		
A	Lamp timer display	Counts down from 365 days to show time for annual lamp replacement.		
B	Lamp timer reset	After installing a new lamp, press and hold for five seconds to reset Lamp timer to 365.		
C	Mute	<ul style="list-style-type: none"> Press to silence audible alarm. When the alarm is due to the lamp's age, the mute button will silence the audible alarm for 7 days; this may be repeated up to a maximum of 4 times. After that, the button will silence for only 24 hours. When the alarm is due to any other issue, the mute button will silence the audible alarm for 24 hours. 		
Indicator Lights				
LED	Green	Yellow	Flashing red	Solid red
1	Controller operating normally	Air temperature around system is too warm.	Controller failure; replace controller.	Controller inactive due to lamp failure.
2	Lamp operating normally	Warning; lamp will require replacement shortly.	<ul style="list-style-type: none"> Lamp disconnected; unplug system, reconnect lamp and plug-in system again. Lamp failure; replace lamp. 	Lamp inactive due to controller failure.
+ models only				
3	UV dose is adequate and sensor is operating normally.	UV dose is near the minimum required.	UV dose is below minimum required, Refer to Section 6.1 . Sensor disconnected; unplug system, reconnect sensor and plug-in system again.	Sensor inactive due to lamp or controller failure.

Section 5 Maintenance

WARNING



- Do not touch the UV lamp directly. It is very hot.
- Do not touch the UV lamp directly. It is very hot.
- Do not touch the UV lamp directly. It is very hot.
- Do not touch the UV lamp directly. It is very hot.

5.1 Replacing UV Lamp

NOTICE

Do not touch the UV lamp directly. It is very hot.

Do not touch the UV lamp directly. It is very hot.

Procedure:

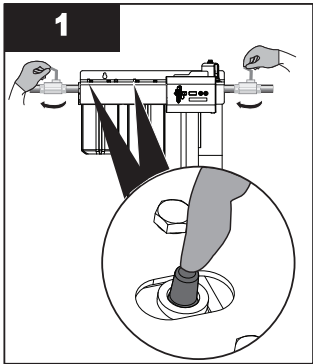

- Turn the top cover clockwise to open the compartment.
- Turn the top cover clockwise to open the compartment.

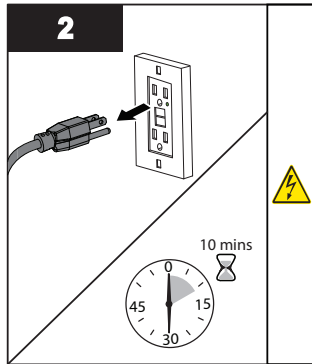

- Disconnect the power cord from the outlet and wait 10 minutes for the lamp to cool down.

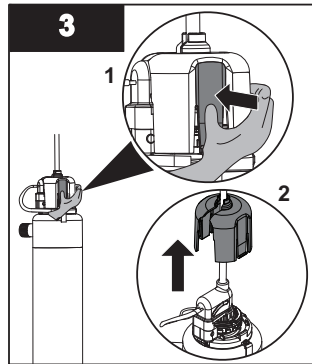

- Turn the lamp counter-clockwise to remove it.
- Note: Ensure the lamp plug wires remain connected.

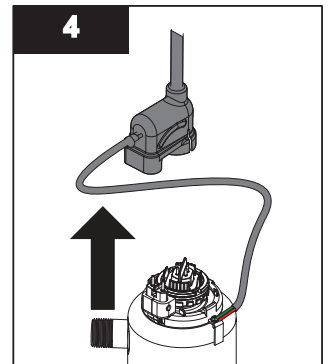

- Turn the lamp clockwise to insert it.
- Note: Ensure the strain relief wires remain connected.

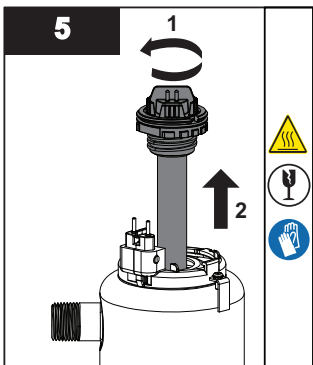

- Turn the top cover clockwise to secure the compartment.

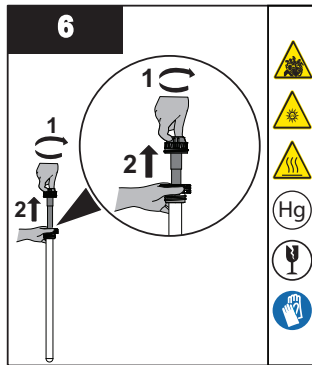

- Do not touch the UV lamp directly. It is very hot.

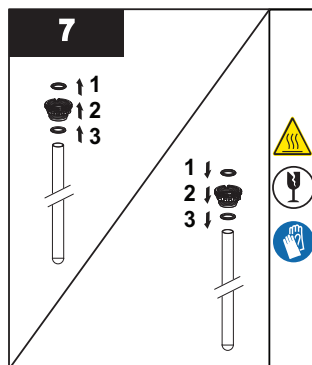

- Turn the lamp counter-clockwise to remove it from the sleeve.
- Do not touch the UV lamp directly. It is very hot.

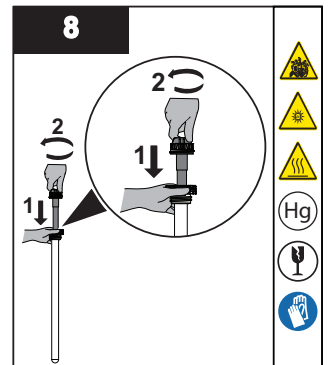

- Turn the lamp clockwise to insert it into the sleeve.
- Note: Over tightening will break the sleeve.

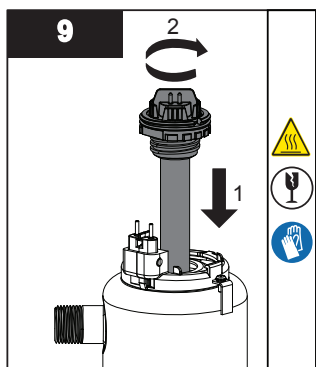

- Insert and secure the lamp/sleeve assembly.

Note: Over tightening will break the sleeve.

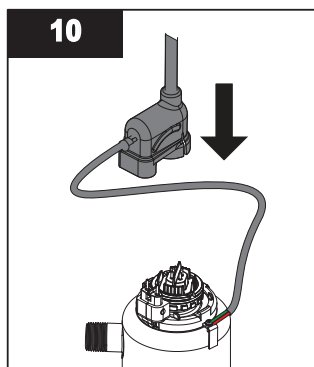

- Connect the green ground wire and red strain relief to the chamber using the grounding screw.
- Align connections by the rotating ring clamp and install the lamp plug.

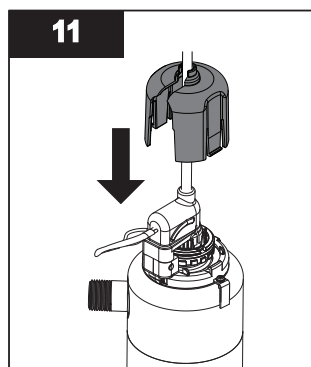

- Insert the safety cap.

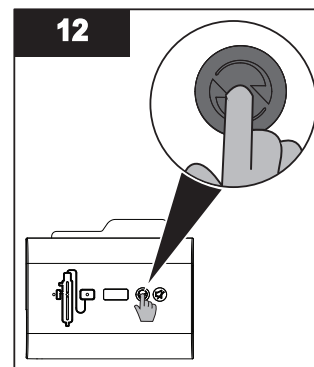

- Restore power.
- If new lamp was inserted, press and hold lamp timer reset button for 5 seconds. Display should read [365].
- Open all faucets and water inlets. Inspect for any leaks.

5.2 Cleaning and Replacing Quartz Sleeve

Note: Minerals in the water slowly form a coating on the quartz sleeve. This coating must be removed because it reduces the amount of UV light reaching the water, thereby reducing disinfection performance. If the sleeve can not be cleaned, it must be replaced.

Prerequisites:

- Shut off water supply and drain all lines.
- Depressurize the unit. Place a small pail under the unit to catch any spills.
- Remove the UV lamp. Refer to [Section 5.1](#).

Procedure:

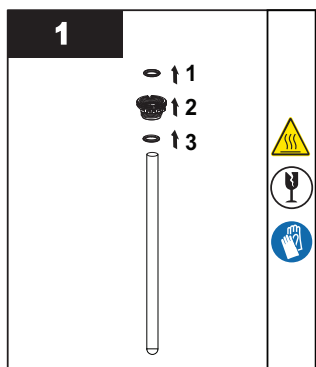

- Unscrew the sleeve bolt and remove O-rings from the quartz sleeve.

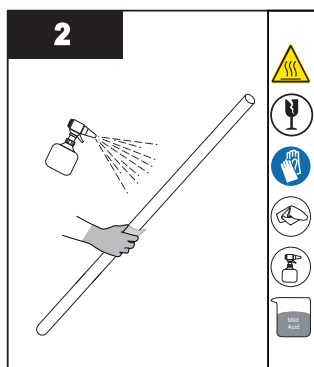

- Clean the quartz sleeve with a cloth soaked in CLR, vinegar or some other mild acid and then rinse with water.
- Note:** If sleeve cannot be cleaned completely or it is scratched or cracked, then replace the sleeve.

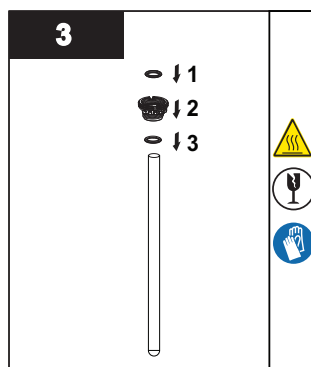

- Insert new O-rings and tighten the sleeve bolt to the quartz sleeve.
- When service is complete, assemble the prerequisites in the reverse order of disassembly.

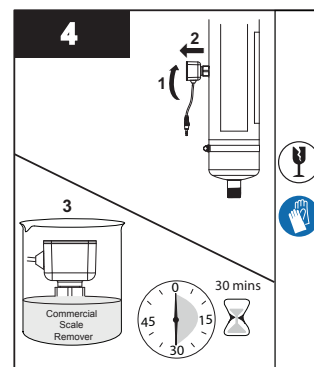

- Remove the UV sensor.
- Submerge the end of sensor for 30 minutes in Commercial Scale Remover and wipe with clean cotton swab.

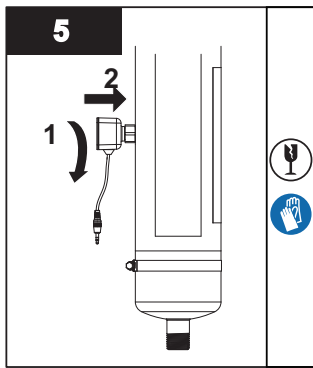

- Reinstall the UV sensor.
- When service is complete, assemble the prerequisites in the reverse order of disassembly.

Notes: 1) After replacing the UV lamp or quartz sleeve perform the disinfection procedure, refer to [Section 3.2](#).

2) If the system is put on a temporary by-pass or if it becomes contaminated after the disinfection system, it is necessary to complete the disinfection procedure, refer to [Section 3.2](#).

Section 6 Troubleshooting

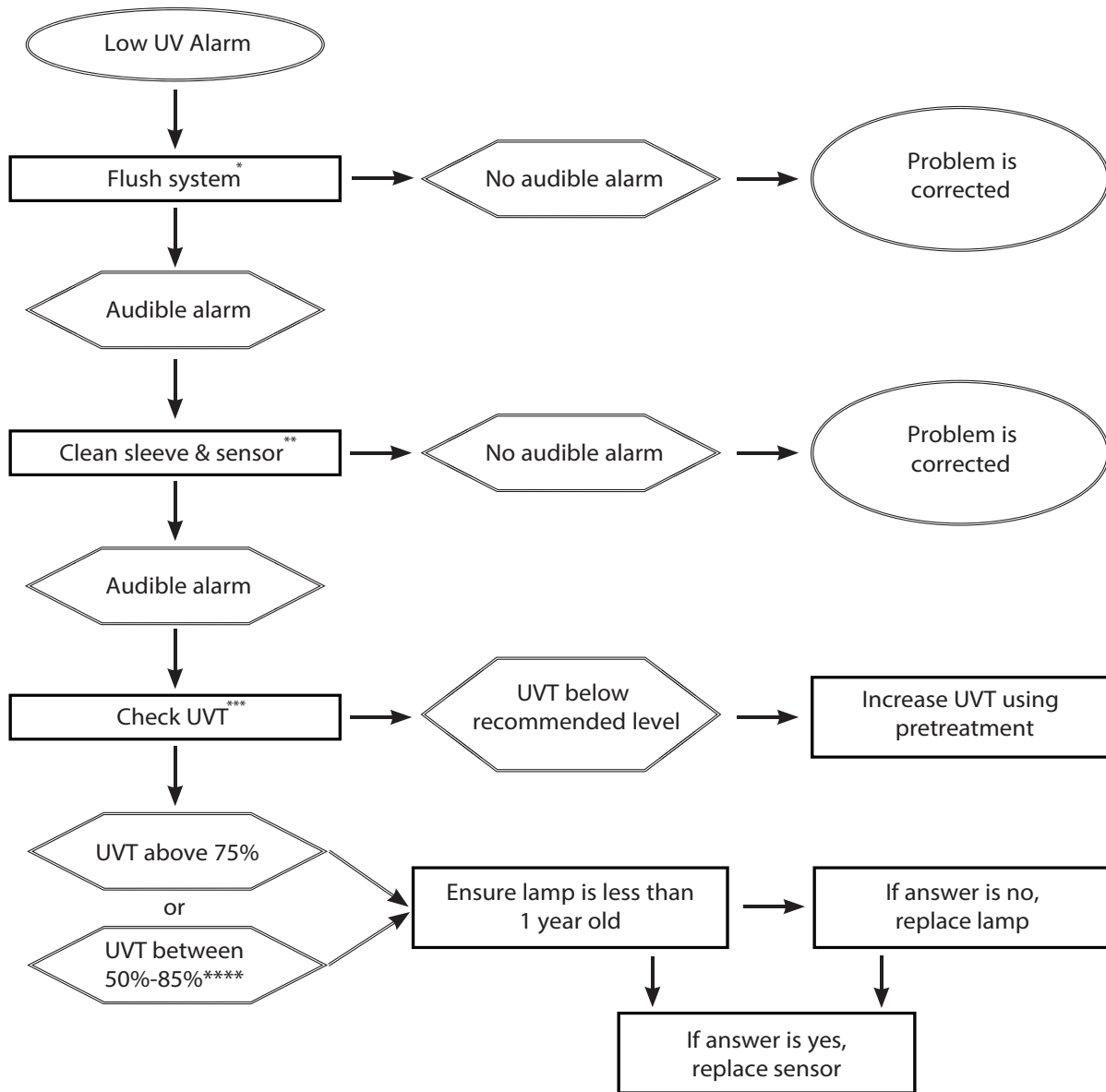

Symptom	Possible Cause	Possible Solution
No power	GFCI and/or breaker tripped	Reset GFCI and/or breaker
	Transient voltage surge suppressor (TVSS) damaged	Replace TVSS
	Controller damaged	Replace controller and use a TVSS
GFCI or breaker repeatedly trips	Connection between lamp and lamp plug is wet	Clean and dry lamp pins and lamp plug, check unit for leaks or condensation
	Short-circuit in the electrical assembly	Replace controller
Leak at inlet or outlet	Threaded pipe fittings are leaking	Clean threads, reseal with Teflon tape and retighten
Leak detected from area of UV chamber	Condensation of moist air on cold chamber (slow accumulation)	Control humidity or relocate unit.
	O-ring damaged, deteriorated or incorrectly installed	Inspect and replace if deteriorated.
	Lamp/sleeve assembly not properly installed (too tight or not tight enough)	Tighten assembly hand-tight.
Leak detected at sensor (if so equipped)	UV sensor O-rings are damaged, deteriorated, or incorrectly installed	Inspect and replace O-rings if deteriorated
Alarm	Refer to Section 4.1 .	Refer to Section 4.1 .
System is operating but water tests reveal bacterial contamination	Equipment downstream of UV system is acting as a breeding ground for pathogens	Ensure UV is the last piece of treatment equipment
	Pathogens are residing in the distribution lines post-UV	Ensure all distribution lines have been disinfected with chlorine. Refer to Section 3.2 .
	Recontamination from pipe dead-ends	Remove any pipe dead-ends and flush with chlorine. Refer to Section 3.2 .
Lamp timer does not read anything	Unit is unplugged.	Plug unit into AC power outlet
	No power at AC power outlet	Replace fuse or reset breaker
	Power cord is damaged	Replace power cord
	Power surge caused damage to electrical assembly	Replace controller and use a surge protector (TVSS)

6.1 Low UV Alarms (+ models only) Certified and Non-certified



*	In some cases, short-term flows of low ultraviolet transmittance (UVT) water can be created following and during the regeneration cycle of a water softener, resulting in a sensor alarm. Flushing the UV system alleviates this condition until the softener goes through another regeneration cycle. In the longer term, the softener's settings must be modified. To flush the UV system, disinfect the water lines. Refer to Section 3.2 .
**	Refer to Section 4.1 .
***	Contact VIQUA or your water treatment dealer for a test of the UVT of the water.
****	For 50%UVT systems if the water UVT is >85%, UV sensor failure alarm will occur. Reducing water UVT will clear this alarm.

Section 7 Specifications

Operating Parameters	General (All Models)	50+ Models	NSF Standard 55 Class B Models (-V)
Maximum operating pressure	125 PSI (862 kPa)	125 PSI (862 kPa)	125 PSI (862 kPa)
Minimum operating pressure	4 PSI (27.5 kPa)	4 PSI (27.5 kPa)	4 PSI (27.5 kPa)
Maximum ambient air temperature	122 °F (50 °C)	122 °F (50 °C)	122 °F (50 °C)
Minimum ambient air temperature	32 °F (0 °C)	32 °F (0 °C)	32 °F (0 °C)
Maximum humidity	100%	100%	100%
Maximum hardness	120 ppm (7 grains per gallon)	120 ppm (7 grains per gallon)	120 ppm (7 grains per gallon)
Maximum iron	0.3 ppm	0.3 ppm	0.3 ppm
UVT	Minimum 75%	50%-85%	Minimum 75%
Installation	Vertical or horizontal*	Vertical or horizontal*	Vertical or horizontal*
Flow Restrictor	-	-	Yes
NSF Certification	-	-	NSF Standard 55 Class B
Rated service life of lamp	1 year	1 year	1 year
UV System Certification			

Model		D4/D4+ D4-V/D4-V+	E4/E4+ E4-V/E4-V+	E4-50+	F4/F4+ F4-V/F4-V+	F4-50+
Flow Rate	Maximum rated flow at dose of 16 mJ/cm ² @ 95% UVT	23 gpm (87 lpm) (5.22 m ³ /hr)	42 gpm (160 lpm) (9.54 m ³ /hr)	-	45 gpm (170 lpm) (10.22 m ³ /hr)	-
	Maximum rated flow at dose of 30 mJ/cm ² @ 95% UVT	12 gpm (45 lpm) (2.73 m ³ /hr)	22 gpm (83 lpm) (5 m ³ /hr)	-	36 gpm (136 lpm) (8.18 m ³ /hr)	-
	Maximum rated flow at dose of 40 mJ/cm ² @ 95% UVT	9 gpm (34 lpm) (2.04 m ³ /hr)	16 gpm (60 lpm) (3.63 m ³ /hr)	-	27 gpm (102 lpm) (6.13 m ³ /hr)	-
	Rated flow for NSF Std 55, Class B (-V versions only)	8.9 gpm (33.7 lpm) (2.02 m ³ /hr)	15.8 gpm (59.8 lpm) (3.6 m ³ /hr)	-	26.1 gpm (98.8 lpm) (5.93 m ³ /hr)	-
	Maximum rated flow at dose of 16 mJ/cm ² @ 50% UVT	-	-	16 gpm (60 lpm) (3.63 m ³ /hr)	-	28 gpm (106 lpm) (6.36 m ³ /hr)
	Maximum rated flow at dose of 30 mJ/cm ² @ 50% UVT	-	-	9 gpm (34 lpm) (2.04 m ³ /hr)	-	15 gpm (57 lpm) (3.4 m ³ /hr)
	Maximum rated flow at dose of 40 mJ/cm ² @ 50% UVT	-	-	7 gpm (26 lpm) (1.6 m ³ /hr)	-	12 gpm (45 lpm) (2.73 m ³ /hr)
Electrical	Voltage	100-240V AC	100-240V AC	100-240V AC	100-240V AC	100-240V AC
	Frequency	50/60 Hz	50/60 Hz	50/60 Hz	50/60 Hz	50/60 Hz
	Max. current	1.0 Amp	1.0 Amp	1.0 Amp	1.0 Amp	1.0 Amp
	Max. power consumption	50 Watts	83 Watts	83 Watts	130 Watts	130 Watts
	Lamp power	40 Watts	70 Watts	70 Watts	110 Watts	110 Watts
Other	UV Chamber Material	304 SST	304 SST	304 SST	304 SST	304 SST
	Inlet/Outlet	3/4" NPT	1" NPT	1" NPT	1" NPT	1" NPT

Section 8 Manufacturer's Warranty

Our Commitment

VIQUA is committed to ensuring your experience with our products and organization exceeds your expectations. We have manufactured your UV disinfection system to the highest quality standards and value you as our customer. Should you need any support, or have questions about your system, please contact our Technical Support team at 1.800.265.7246 or technicalsupport@viqua.com and we will be happy to assist you. We sincerely hope you enjoy the benefits of clean, safe drinking water after the installation of your VIQUA disinfection system.

How to Make a Warranty Claim

Note: *To maximise the disinfection performance and reliability of your VIQUA product, the system must be properly sized, installed and maintained. Guidance on the necessary water quality parameters and maintenance requirements can be found in your Owner's Manual.*

In the event that repair or replacement of parts covered by this warranty are required, the process will be handled by your dealer. If you are unsure whether an equipment problem or failure is covered by warranty, contact our Technical Support team at 1.800.265.7246 or e-mail technicalsupport@viqua.com. Our fully trained technicians will help you troubleshoot the problem and identify a solution. Please have available the model number (system type), the date of purchase, the name of the dealer from whom you purchased your VIQUA product ("the source dealer"), as well as a description of the problem you are experiencing. To establish proof of purchase when making a warranty claim, you will either need your original invoice, or have previously completed and returned your product registration card via mail or online.

Specific Warranty Coverage

Warranty coverage is specific to the VIQUA range of products. Warranty coverage is subject to the conditions and limitations outlined under "[General Conditions and Limitations](#)".

Ten-Year Limited Warranty for VIQUA UV Chamber

VIQUA warrants the UV chamber on the VIQUA product to be free from defects in material and workmanship for a period of ten (10) years from the date of purchase. During this time, VIQUA will repair or replace, at its option, any defective VIQUA UV chamber. Please return the defective part to your dealer who will process your claim.

Three-Year Limited Warranty for Electrical and Hardware Components

VIQUA warrants the electrical (controller) and hardware components to be free from defects in material and workmanship for a period of three (3) years from the date of purchase. During this time, VIQUA will repair or replace, at its option, any defective parts covered by the warranty. Please return the defective part to your dealer who will process your claim.

One-Year Limited Warranty for Lamps, Sleeves, and UV Sensors

VIQUA warrants lamps, sleeves, and UV sensors to be free from defects in material and workmanship for a period of one (1) year from the date of purchase. During this time, VIQUA will repair or replace, at its option, any defective parts covered by the warranty. Your dealer will process your claim and advise whether the defective item needs to be returned for failure analysis.

Note: *Use only genuine VIQUA replacement lamps and sleeves in your system. Failure to do so may seriously compromise disinfection performance and affect warranty coverage.*

General Conditions and Limitations

None of the above warranties cover damage caused by improper use or maintenance, accidents, acts of God or minor scratches or imperfections that do not materially impair the operation of the product. The warranties also do not cover products that are not installed as outlined in the applicable Owner's Manual.

Parts repaired or replaced under these warranties will be covered under warranty up to the end of the warranty period applicable to the original part.

The above warranties do not include the cost of shipping and handling of returned items

The limited warranties described above are the only warranties applicable to the VIQUA range of products. These limited warranties outline the exclusive remedy for all claims based on a failure of or defect in any of these products, whether the claim is based on contract, tort (including negligence), strict liability or otherwise. These warranties are in lieu of all other warranties whether written, oral, implied or statutory. Without limitation, no warranty of merchantability or of fitness for a particular purpose shall apply to any of these products.

VIQUA does not assume any liability for personal injury or property damage caused by the use or misuse of any of the above products. VIQUA shall not in any event be liable for special, incidental, indirect or consequential damages. VIQUA's liability shall, in all instances, be limited to repair or replacement of the defective product or part and this liability will terminate upon expiration of the applicable warranty period.



425 Clair Rd. W, Guelph, Ontario, Canada N1L 1R1
t. (+1) 519.763.1032 • tf. (+1) 800.265.7246 (US and Canada only)
t. (+31) 73 747 0144 (Europe only) • f. (+1) 519.763.5069
e-mail: info@viqua.com
www.viqua.com